

MULTI SPLIT TYPE, HEAT PUMP AIR CONDITIONERS



# Technical service manual

R410A Duct Inverter multi Series

## Indoor Models

**SMF-D07AI**

**SMF-D09AI**

**SMF-D12AI**

**SMF-D18AI**

## Outdoor Models

**SMF-4E27AI**

**SINCLAIR**

## **CONTENTS**

- 1. Features**
- 2. Specification**
- 3. Outline and dimension**
- 4. Indoor unit combination**
- 5. Capacity table**
- 6. Wiring diagram**
- 7. Electronic control function**
- 8. Exploded view**

## 1. Features:

- 1) All plastic body, small weight and anti-corrosion;
- 2) Low operation noise;
- 3) Adopt cross fan;
- 4) Compact structure, space saving.



## 2.Specification

### indoor unit

Model			SMF-D07AI	SMF-D09AI	SMF-D12AI	SMF-D18AI
Power supply		Ph-V-Hz	1Ph,220-240V~,50Hz	1Ph,220-240V~,50Hz	1Ph,220-240V~,50Hz	1Ph,220-240V~,50Hz
Capacity	Cooling Capacity	BTU/h	7,000	9,000	12,000	18,000
	Heating Capacity	BTU/h	8,500	11,000	13,000	20,500
	Power input	w	40	40	45	60
	Design Pressure (Hi/Lo)	Mpa	4.2/2.5	4.2/2.5	4.2/2.5	4.2/2.5
	Max. Operating Pressure	Mpa	3.7	3.7	3.7	3.7
Indoor fan motor	Model		RPS20D	RPS20D	RPS20D	YDK45-4F
	Brand		Welling	Welling	Welling	Welling
	Input	W	38	38	38	63
	Capacitor	uF	1.0uF/450V	1.0uF/450V	1.0uF/450V	2.5uF/450V
	Speed(hi/mi/lo)	r/min	735/650/560	735/650/560	735/650/560	930/830/660
Indoor coil	a.Number of rows		2	2	2	2
	b.Tube pitch(a)x row pitch(b)	mm	21x13.37	21x13.37	21x13.37	25.4x22
	c.Fin spacing	mm	1.5	1.5	1.5	1.7
	d.Fin type (code)		Hydrophilic aluminium	Hydrophilic aluminium	Hydrophilic aluminium	Hydrophilic aluminium
	e.Tube outside dia.and type	mm	Φ7, innergroove tube	Φ7, innergroove tube	Φ7, innergroove tube	Φ9.53, innergroove tube
	f.Coil length x height x width	mm	700X26X350	700X26X350	700X26X350	800X254X44
	g.Number of circuits		4	4	4	3
Indoor air flow (Hi/Mi/Lo)		m3/h	480/410/360	480/410/360	580/480/400	660/550/480
Indoor noise level (Hi/Mi/Lo)		dB(A)	35/32/30	36/33/30	38/35/33	40/38/35
Pipe size	Liquid side/ Gas side	mm(inch)	φ6.35 (1/4')	φ6.35 (1/4')	φ6.35 (1/4')	φ6.35 (1/4')
			φ9.53 (3/8')	φ9.53 (3/8')	φ12.7 (1/2')	φ12.7 (1/2')
Indoor unit	Dimension (W*H*D)	mm	955×210×385	955×210×385	955×210×385	1301X210X385

	Packing (W*H*D)	mm	1044X277X439	1044X277X439	1044X277X439	1388X277X439
	Net/Gross weight	Kg	15/19	15/19	15/19	18/22
Application area		m <sup>2</sup>	10-14	14-21	18-26	35-40
Qty per 20'/40'/40'HQ		Pieces				

## OUTDOOR UNIT:

Outdoor Model			SMF-4E27AI			
Indoor unit combination			single	double	Treble	Quadplex
Power supply		Ph-V-Hz	1Ph,220-240V~,50Hz			
Cooling	Cooling Capacity range	Btu/h	7000~18000	14000~24000	21000~26000	27000
	Rated input power range	W	960~2510	1450~2830	2050~3100	3141
	Rated current range	A	4.4~12.0	6.6~13.0	9.4~14.6	14.8
Heating	Heating Capacity range	Btu/h	9000~18000	16000~25000	21000~27000	28000
	Rated input power range	W	1100~2430	1400~2520	2020~3000	3050
	Rated current range	A	5.0~11.6	6.4~12.0	9.3~13.8	13.9
Max. input consumption		W	4500			
Max. current		A	25			
Compressor	Model		BA160X2CS-20KU			
	Type		Rotary inverter			
	Brand		GD Toshiba			
	Capacity	Btu/h	18000(60HZ)			
	Input	W	1690 (60HZ)			
	Rated current(RLA)	A	11.6 (60HZ)			
	Locked rotor Amp(LRA)	A	60			
	Thermal protector		Internal			
	Capacitor	uF	85UF/250V			
	Refrigerant oil	ml	RB68AF/α68TF/T-68 750 ml			
Outdoor motor fan	Model		YDK100-6			
	Brand		Welling			
	Input	W	169(HIGH)			
	Capacitor	uF	5uF/500VAC			
	Speed	r/min	900(HIGH)			

Outdoor coil	a.Number of rows		2
	b.Tube pitch(a)x row pitch(b)	mm	25.4×22
	c.Fin spacing	mm	1.5
	d.Fin type (code)		Hydrophilic aluminium
	e.Tube outside dia.and type	mm	φ9.53 innergroove tube
	f.Coil length x height x width	mm	850×810×44
	g.Number of circuits		2
Outdoor air flow		m <sup>3</sup> /h	3500
Outdoor noise level		dB(A)	57
Outdoor unit	Dimension(W*H*D)	mm	895X860X330
	Packing (W*H*D)	mm	1043X915X395
	Net/Gross weight	Kg	80/84
Refrigerant type and charge		g	R410A, 2700
Design pressure(Hi/Lo)		MPa	4.2/2.5
Refrigerant piping	Liquid side/ Gas side	mm(inch)	6.35(1/4)/9.53(3/8)
	Max. refrigerant pipe length for each unit	m	20
	Max. difference in level between indoor and outdoor unit	m	10
Connection wiring			No
Plug type			No
Thermostat type			Electronic control
Operation temp	Cooling	°C	17~43
	heating	°C	-7~21
Qty'per 20' /40' /40'HQ		set	

Notes:

- Nominal cooling capacities are based on the following conditions:  
Indoor temp: 27°CDB, 19°CWB;

Outdoor temp: 35°CDB;

Equivalent ref. Piping: 8m(horizontal)

Outdoor operating frequency:78Hz

Indoor combination:7K X4, setting temp.:17°C,setting fan speed: high speed.

2. Nominal heating capacities are based on the following conditions:

Indoor temp: 20°CDB;

Outdoor temp: 7°CDB, 6°CWB;

Equivalent ref. Piping: 8m(horizontal)

Outdoor operating frequency:85Hz

Indoor combination:7K X4, setting temp.:30°C,setting fan speed: high speed.

3. Actual noise level may differ, depending on the room structure, etc, since these noise values are from an anechoic room.

### 3. Outline and dimension

#### Indoor unit: 7/9/12k

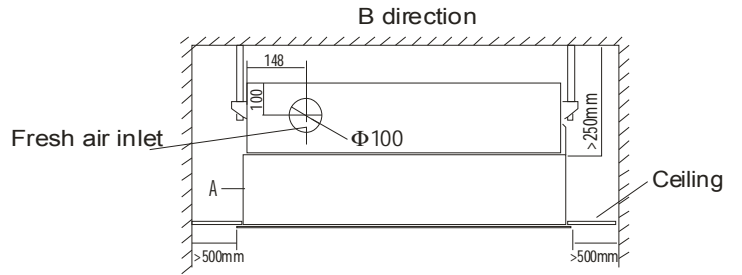
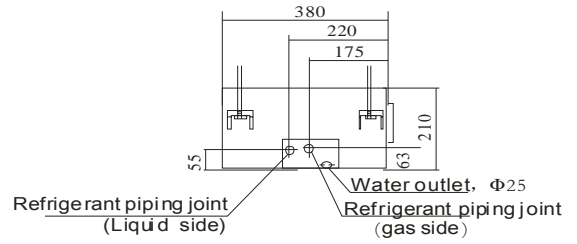
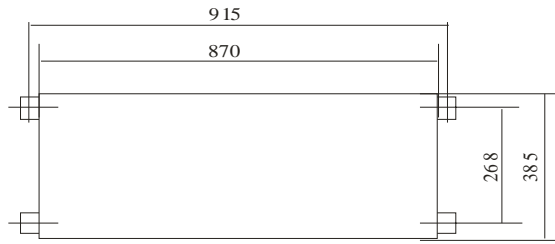
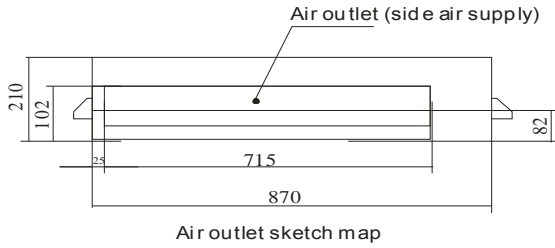

#### Indoor unit 18k

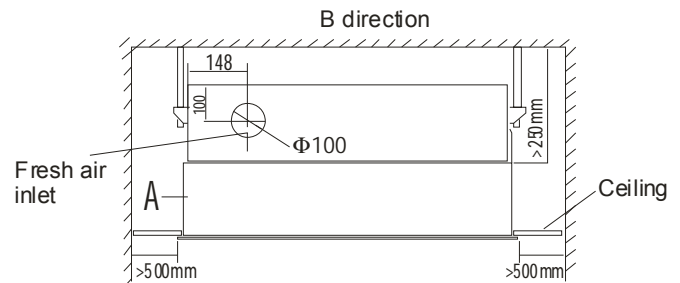
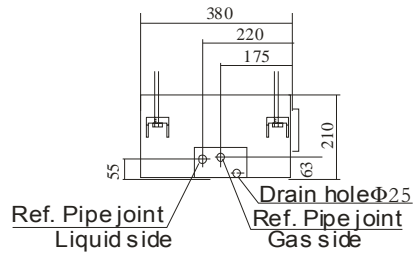
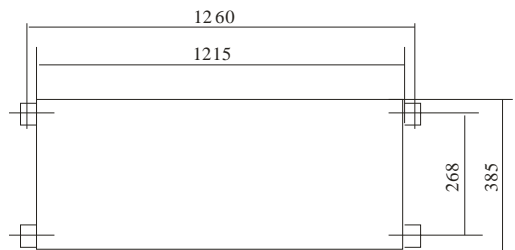
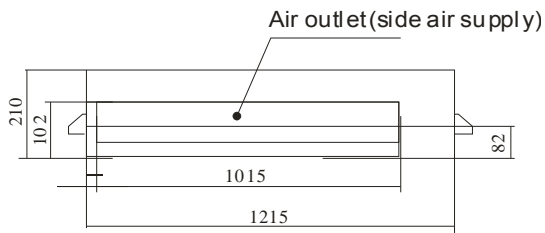

#### Outdoor unit:

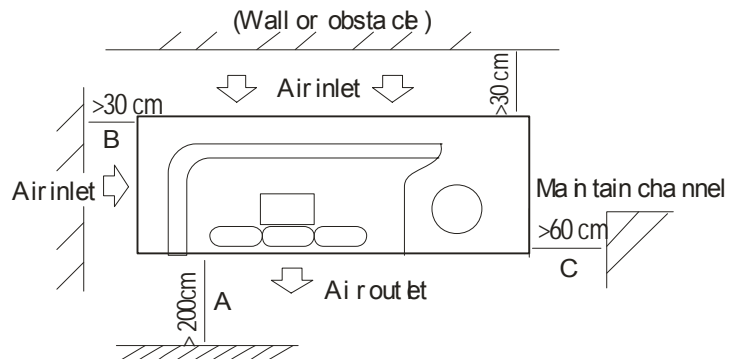
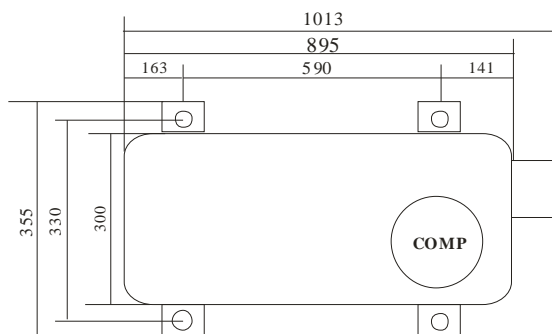

## 4. Indoor unit combination

### Caution on combination

The one-drive-four outdoor unit SMF-E427AI nominal cooling capacity is 8kw(under condition of ambient temp. 35°Cdb/24°Cwb, indoor temp. 27°Cdb/19°Cwb). According to refrigeration design criterion, total indoor unit capacity should be equal to outdoor capacity, otherwise, we can not guarantee best performance and safe operation. Although, we made special design on refrigeration system regarding customer's requirements. Based on this, when indoor total capacity exceed outdoor capacity, the machine can still run. Under this condition, the single indoor unit capacity will attenuate. That means you can not gain the nominal capacity, but smaller than it. We are out of responsibility if customers don't follow the notice below:

1. You can connect two, three or four indoor units according your need;
2. The total indoor unit nominal capacity should not exceed 11.3kw(42% more than nominal capacity);
3. There should be no more one 18k indoor unit(either cassette or duct), and other indoor unit should be all 7k;
4. There should be no more two duct indoor units, and other indoor units should be all wall mounted;
5. There should be no more one cassette;
6. Cassette and duct can not be installed simultaneously.
7. When heating, capacity attenuate sharply if indoor unit capacity exceed too much.

## 5. Capacity table

SMF-4E27AI (7k+7k+7k+7k)

<b>COOLING</b>		<b>OUTDOOR TEMPERATURE DRY</b>					
<b>Indoor Conditions</b>		<b>21°C</b>	<b>25°C</b>	<b>30°C</b>	<b>35°C</b>	<b>40°C</b>	<b>45°C</b>
21°C D 15°C W	Total capacity kW	7.63	7.30	7.03	6.64	6.37	6.17
	Sensitive capacity kW	6.11	5.84	5.63	5.31	5.10	4.94
	Input kW.	1.95	2.23	2.51	2.79	3.07	3.35
24°C D 17°C W	Total capacity kW	8.36	7.99	7.70	7.27	6.98	6.76
	Sensitive capacity kW	6.69	6.40	6.16	5.81	5.58	5.41
	Input kW.	2.06	2.36	2.65	2.95	3.24	3.53
27°C D 19°C W	Total capacity kW	9.09	8.69	8.37	<b>7.90</b>	7.58	7.35
	Sensitive capacity kW	7.27	6.95	6.70	6.32	6.07	5.88
	Input kW.	2.17	2.48	2.79	<b>3.10</b>	3.41	3.72
32°C D 23°C W	Total capacity kW	10.45	9.99	9.63	9.09	8.72	8.45
	Sensitive capacity kW	8.36	7.99	7.70	7.27	6.98	6.76
	Input kW.	2.50	2.85	3.21	3.57	3.92	4.28

<b>HEATING</b>		<b>OUTDOOR CONDITIONS</b>							
<b>Indoor Conditions</b>		<b>24°C D</b>	<b>12°C D</b>	<b>7°C D</b>	<b>4°C D</b>	<b>0°C D</b>	<b>-5°C D</b>	<b>-7°C D</b>	<b>-15°C D</b>
		<b>18°C W</b>	<b>11°C W</b>	<b>6°C W</b>	<b>3°C W</b>	<b>-1°C W</b>	<b>-6°C W</b>	<b>-8°C W</b>	<b>-16°C W</b>
15°C	Capacity kW	14.66	11.73	9.78	8.80	8.31	7.33	6.84	6.35
	Input kW.	5.52	4.42	3.68	3.50	3.31	3.13	2.94	2.58
18°C	Capacity kW	13.77	11.02	9.18	8.26	7.80	6.89	6.43	5.97
	Input kW.	5.18	4.15	3.46	3.28	3.11	2.94	2.76	2.42
20°C	Capacity kW	12.75	10.20	<b>8.50</b>	7.65	7.23	6.38	5.95	5.53
	Input kW.	4.80	3.84	<b>3.20</b>	3.04	2.88	2.72	2.56	2.24
22°C	Capacity kW	11.73	9.38	7.82	7.04	6.65	5.87	5.47	5.08
	Input kW.	4.42	3.53	2.94	2.80	2.65	2.50	2.36	2.06
27°C	Capacity kW	10.20	8.16	6.80	6.12	5.78	5.10	4.76	4.42
	Input kW.	3.84	3.07	2.56	2.43	2.30	2.18	2.05	1.79

## 6. Wiring diagram

### Indoor unit:

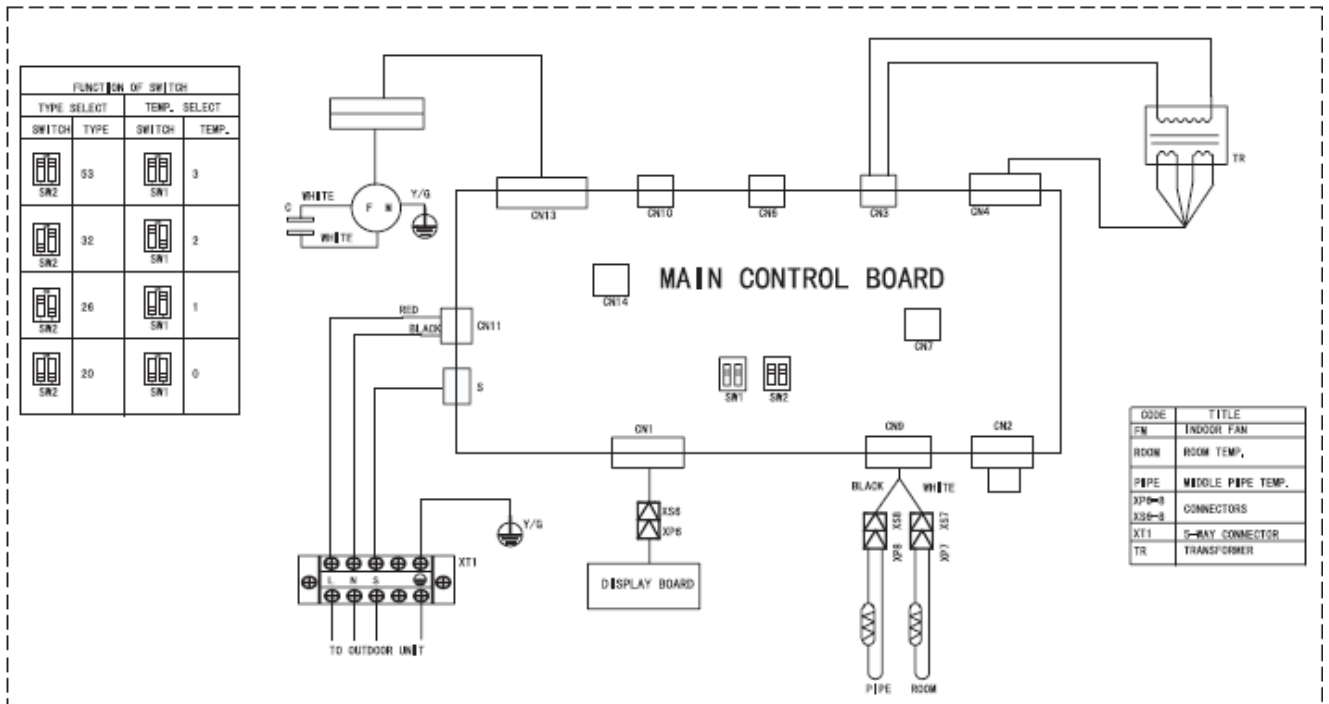

# Outdoor unit:

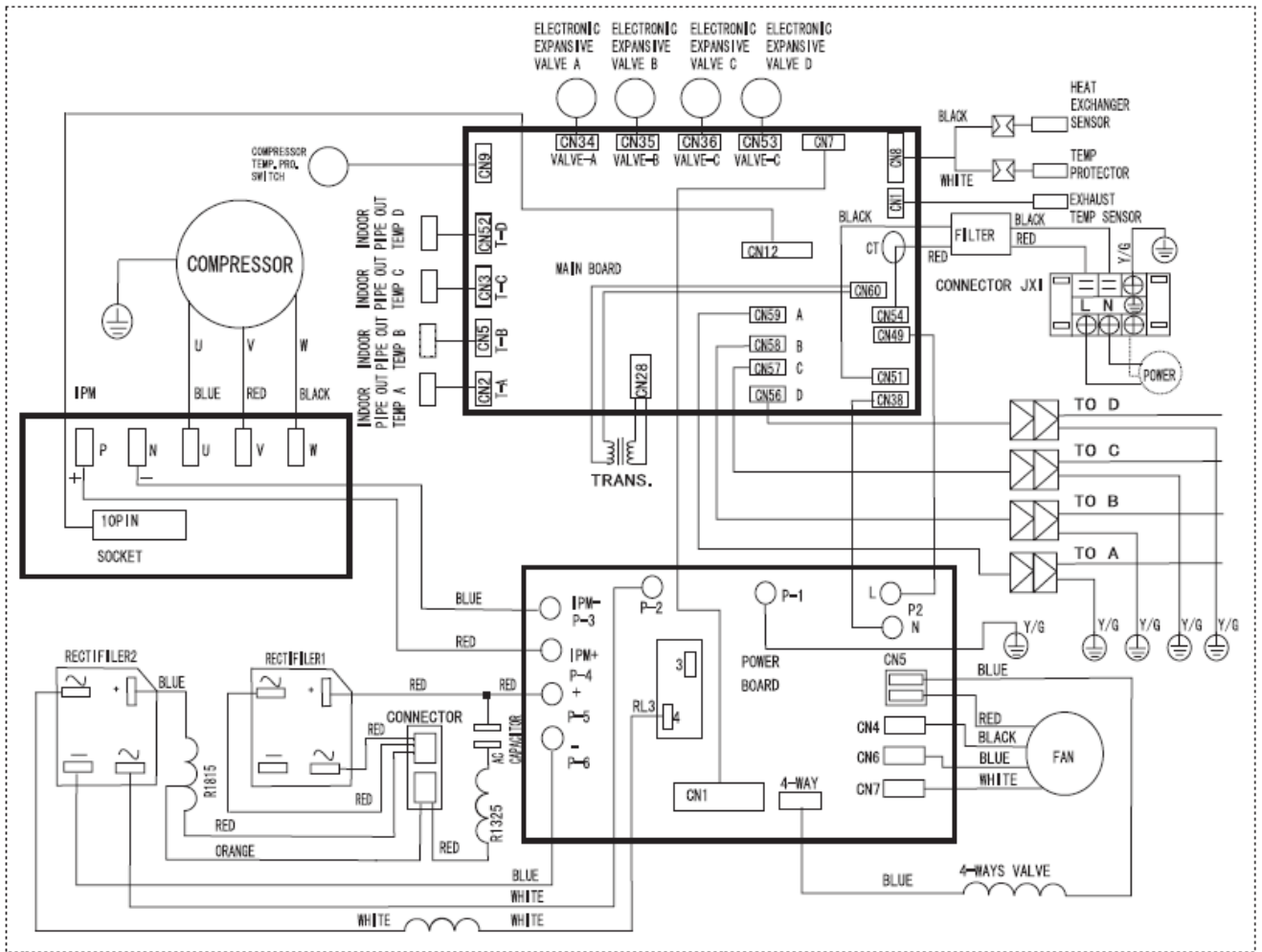

## 7. Electric control functions:

### 7.1 Protection

1. 3 minutes delay at restart for compressor.
2. Temperature protection of compressor top, compressor stops when the temp. of top of compressor is more than 120°C, compressor runs when the temp. of top of compressor is less than 105°C.
3. When AC voltage  $\geq 270V$  for 30 seconds, Outdoor Unit stops operation and alarms. When AC voltage  $\leq 260V$  for 30 seconds, Outdoor Unit resumes operation.
4. Inverter module protection, Inverter module Protection itself has a protection function against current, voltage and temperature.
5. Sensor protection at open circuit and breaking disconnection.
6. Fan Speed is out of control. When Indoor Fan Speed is too high(higher than High Fan+300RPM)or too low(lower than 400RPM), the unit stops and LED displays failure information and can't return to normal operation automatically.
7. Cross Zero signal error warning. If there is no Cross Zero signals in 4 minutes, the unit stops and LED displays failure information and can't return to normal operation automatically.
8. Current protection: When the current is more than 25A, the compressor stops.
9. Outdoor condenser high temperature protection: Under cooling mode, if  $T_3 > 65^\circ C$  for 3 minutes, the compressor will stop. When  $T_3 < 52^\circ C$ , the protection is not valid.
10. Outdoor low temperature protection: If the outdoor temperature is lower than  $-15^\circ C$  for 1hour, the compressor and fan motor will stop. If the outdoor temperature is higher than  $-12^\circ C$  for 10 minutes and the compressor stops operation for 1h, or the outdoor temperature is higher than  $5^\circ C$  for 10 minutes, then restart and enter into the prior operation mode.
11. Compressor pre-heating function: When the outdoor temperature is lower than  $3^\circ C$  and the compressor stops operation for more than 3 hours, or the outdoor temperature is lower than  $3^\circ C$  and the power is just put on, the compressor enters into pre-heating condition. When outdoor temp. is more than  $5^\circ C$  or user operate it, pre-heating condition will finish.

## 7.2 Operating mode

### 7.2.1 Cooling mode

1. Indoor fan keeps running, fan speed can be set in high/mid/low/ Auto:

2. Auto fan at cooling mode: (T=Indoor Temp.-Setting Temp.)

	Condition	Indoor fan speed
Room temp. up	$T < 1.5^\circ C$	Low
	$1.5^\circ C < T < 4^\circ C$	Mid.
	$T > 4^\circ C$	High
Room temp. down	$T > 3^\circ C$	High
	$1^\circ C < T < 3^\circ C$	Mid.
	$T < 1^\circ C$	Low

3. Anti-freezing control to indoor evaporator at cooling mode( T: evaporator temp. )

	Evaporator Temp.	Compressor
	$T < 4^\circ C$	Off
	$T > 8^\circ C$	On

### 7.2.2 Dehumidifying mode

1. The indoor fan is fixed in low speed
2. Low room temperature protection:  
When room temperature decreases to below 10°C, indoor fan stop, when room temperature restores to over 12°C, indoor fan start.
3. At dehumidifying mode, the anti-freezing function of the indoor heat exchanger is the same as that of cooling mode.

### 7.2.3 Heating mode

1. Indoor Fan actions at heating mode  
Indoor Fan can be set at HIGH/MID/LOW/AUTO by using a remote controller, but Anti-cold wind function prevails.

Anti-cold wind control function at heating mode

	Condition T= Indoor exchanger temp.	Indoor fan speed
Indoor exchanger temp. up	T<34°C	Off
	34°C<T<37°C	Breeze
	37°C<T<44°C	Low speed
	T>44°C	Setting fan speed
Indoor exchanger temp. down	T>38°C	Setting fan speed
	33°C<T<38°C	Low speed
	24°C<T<33°C	Breeze
	T<24°C	Off

1. Auto wind at heating mode

	Condition T=Indoor Temp.-Setting Temp.	Indoor fan speed
Room temp. up	T<1.5°C	High
	1.5°C<T<2.5°C	Mid.
	T>2.5°C	Low
Room temp. down	T<1.0°C	High
	1.0°C<T<2.0°C	Mid.
	T>2.0°C	Low

2. Indoor evaporator high-temperature protection at heating mode

Condition T= Indoor exchanger temp.	Compressor
T<48°C	On
53°C<T<63°C	Decrease frequency of compressor
T>63°C	Off

### 7.2.4 Defrost operation

1. Defrosting condition:  
The temperature of outdoor heat exchanger remains consecutively lower than -2°C for more than 40 minutes,
2. Ending condition of defrosting

If one of following conditions is satisfied, end the defrost and turn into heating mode:

- a. The defrost time has reached to 10 minutes.
- b. When the temperature of outdoor heat exchanger rises up to 15°C.

3. Defrosting Actions:

- a. Compressor runs.
- b. 4 way valve switches off,
- c. Outdoor fan switches off
- d. Indoor fan running according to anti-cold wind function in heating mode.

4. Automatic operation mode

The air conditioner automatically selects one of the following operation modes: cooling, heating or fan only according to the temp. difference between room temp. (TA) and set temp. (TS).

TA—TS	Operation mode
TA—TS>2°C	Cooling
-1°C≤TA-TS≤+2°C	Fan-only
TA-TS<-1°C	Heating (air-only for cooling only type)

7.3 Mode conflict

The indoor units can not work cooling mode and heating at same time. Heating mode has a priority.

7.3.1 Definition

	Cooling mode	Heating Mode	Fan	Off
Cooling mode	No	Yes	No	No
Heating Mode	Yes	No	Yes	No
Fan	No	Yes	No	No
Off	No	No	No	No

No: No mode conflict;

Yes: Mode conflict

7.3.2 In case of one Indoor unit working in cooling mode or fan mode, and another indoor unit is set to heating mode, the indoor unit working in cooling mode or fan mode will change to stand by. The outdoor unit will work in heating mode.

7.3.3 In case of one Indoor unit working in heating mode, and another indoor unit is set to cooling mode or fan mode, the indoor unit setting to cooling mode or fan mode will change to stand by.

7.4 Manual switch

Mode changes when push this button.

Cooling mode → Auto mode → Unit off → Cooling mode

At Cooling mode, after 30 minutes cooling operation whose fan speed is set as low, the A/C operates with a setting temp. of 24°C.

At auto mode, the A/C operates with a set temp. of 24°C

7.5 Timer Function

1. The maximum length of timer is 24 hours and the minimum resolving power is 15 minutes.
2. Timer on: first turn off the A/C, the A/C will be automatically on at the set time.
3. Timer off: first turn on the A/C, the A/C will be automatically off at the set time
4. Timer on/off function( on time is earlier than off time): first turn off the A/C, it will be automatically on at set time, and later be off at the set time, then unit turns on at set time.
5. Timer off/on function( off time is earlier than on time): first turn on the A/C, it will be automatically off at set time, and later be on at the set time, then unit turns off at set time.

## 7.6 Auto restart function

In case of a sudden power failure, this function automatically sets the unit to previous settings before the power failure when power returns.

## 7.7 Cooling capacity test frequency locked.

When test the cooling capacity, the frequency can be locked at 78Hz by following the below:

1. Set the indoor temp. to 17°C and high speed;
2. Push the outdoor check button for 5 seconds, then its frequency can be fixed at 78Hz.

After the test is over, turn off the indoor to exit.

When test the heating capacity, the frequency can be locked at 85Hz by following the below:

1. Set the indoor temp. to 30°C and high speed;
2. Push the outdoor check button for 5 seconds, then its frequency can be fixed at 78Hz.

After the test is over, turn off the indoor to exit.

## 7.8 Indoor unit indicator display function:

Operation	Timer	De-frost	Alarm	State
★	X	X	X	Indoor room temp. sensor open or short-circuit
X	X	★	X	Indoor pipe temp. sensor open or short-circuit
X	★	X	X	Indoor and outdoor communication error
X	X	X	★	Water level alarm
★	★	X	X	EEPROM error
★	X	X	●	Inverter module protection
★	●	X	X	Outdoor sensor open or short circuit
★	●	X	●	Outdoor voltage protection
★	X	●	X	Compressor top temp. protection
★	X	●	●	Mode conflict
★	X	★	★	Outdoor current protection

★ flash, ● light, X extinguished.

## 7.9 Outdoor unit LED display function:

1. When stand-by it display number of indoor unit online;
2. When operation it display frequency of outdoor unit;
3. When defrost it display “df”;
4. When a protection or error occurred, it display as the following table:

Display	Explanation
E0	EEPROM error
E1	No 1 Indoor units pipe temp. sensor or connector of pipe temp. sensor is defective
E2	No 2 Indoor units pipe temp. sensor or connector of pipe temp. sensor is defective
E3	No 3 Indoor units pipe temp. sensor or connector of pipe temp. sensor is defective
E4	Outdoor temp. sensor or connector of temp. sensor is defective
E5	Compressor voltage protection
E6	No 4 Indoor units pipe temp. sensor or connector of pipe temp. sensor is defective
E7	Indoor and outdoor communication error
P0	Compressor top protection against temperature
P1	High pressure protection
P2	Low pressure protection
P3	Compressor current protection
P4	Inverter module protection
P5	Outdoor low temp. protection
P6	Condenser high-temperature protection

## 7.10 Check function:

There is a check button on outdoor pcb. When push this button, the outdoor LED can display in sequence:

Capacity demand→Running mode →revised capacity → fan state →No.1 evaporator pipe temp. →No.2 evaporator pipe temp.→No.3 evaporator pipe temp.→No.4 evaporator pipe temp.→outdoor pipe temp. → Outdoor temp. →discharge gas temp.→current of outdoor unit → No. 1 opening degree of electronic expansion valve → No. 2 opening degree of EXV → No. 3 opening degree of EXV→No. 4 opening degree of EXV→indoor unit number→last protection/error code→capacity demand(cycle)

Explanation for the some display content:

1. Running mode:

Display	Corresponding mode
0	Off
1	Cooling mode
2	Heating mode

## 2. Fan state:

Display	Corresponding mode
0	Off
1	Low fan
2	High fan

## 3. Opening degree of EXV:

Opening degree equals the display data times 8;

## 4. Number of indoor unit

The indoor unit that can communicate with outdoor unit normally.

## 7.11 Outdoor fan speed control

There is one fan with two-speed, the fan speed is controlled according ambient temp. After the compressor stop, 30 seconds later the fan stop.

When cooling:

Ambient temp.rise	> 27	High speed
	<27	Low speed
Ambient temp.decline	>25	High speed
	<25	Low speed

When heating:

Ambient temp.rise	> 14	Low speed
	<14	High speed
Ambient temp.decline	>12	Low speed
	<12	High speed

## 7.12 Oil return function

If operation frequency is lower than 54Hz in 2 hours consecutively, it will be increased to 62Hz for 3 minutes. Then it recovers to the former operation frequency.

## 8. Exploded view

SMF-D07/09AI

Exploded View Parts

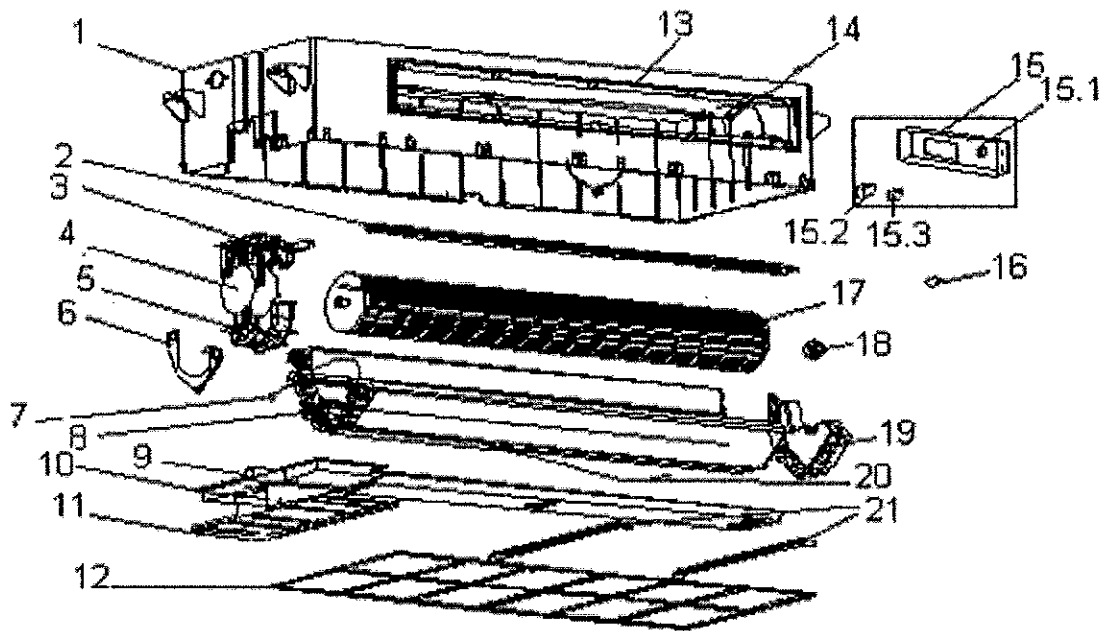

No.	Part Name	Quantity	SALE CODE	BOM CODE
1	Base Plate	1	50412121004	2118510030
2	Volute organ	1	50412121005	2118615010
3	Holder for fan motor	1	50412121006	2118615002
4	Motor	1	50412121007	2240038002
5	Cover for motor	1	50412121008	2118615003
6	Joint board of Evaporator	1	50412121009	2128615005
7	Evaporator out temperature sensor	1	50224121048	2244200406
8	Evaporator assembly	1		2155229000
9	Outlet pipe	1	31009321020	2112040701
10	Water collector	1	50412121011	2118510031
11	Protection cover of water collector	1	50412121012	2128615001
12	Air filter	1	50412121013	2118615004
13	Air-passage installation board	1	50412121014	2128000023
14	Room temperature senior	1	53930121801	2230131063
15	Indoor E-box	1		2335229000
15.1	Transformer	1	50448122007	2230090093
15.2	Capacitor box	1	50526121004	2128000014
15.3	Fan capacitor	1	52503121007	2240110004
15.4	Main control board	1		2135229000
16	Display board assembly	1	50518121028	2334209023
17	Centrifugal fan	1	50412121016	2118615005

18	Bearing seat	1	12818111015	2273050001
19	Left fixing board of evaporator	1	50412121017	2118615008
20	Evaporator middle temperature sensor	1	50412121018	2248615220
21	Fixing clamp for water collector	2	50412121019	2128615000
22	Remote controller	1	10718121008	2335509100
23	Holder for remote controller	1	10718121009	2113139022

### SMF-D12AI

#### Exploded View Parts

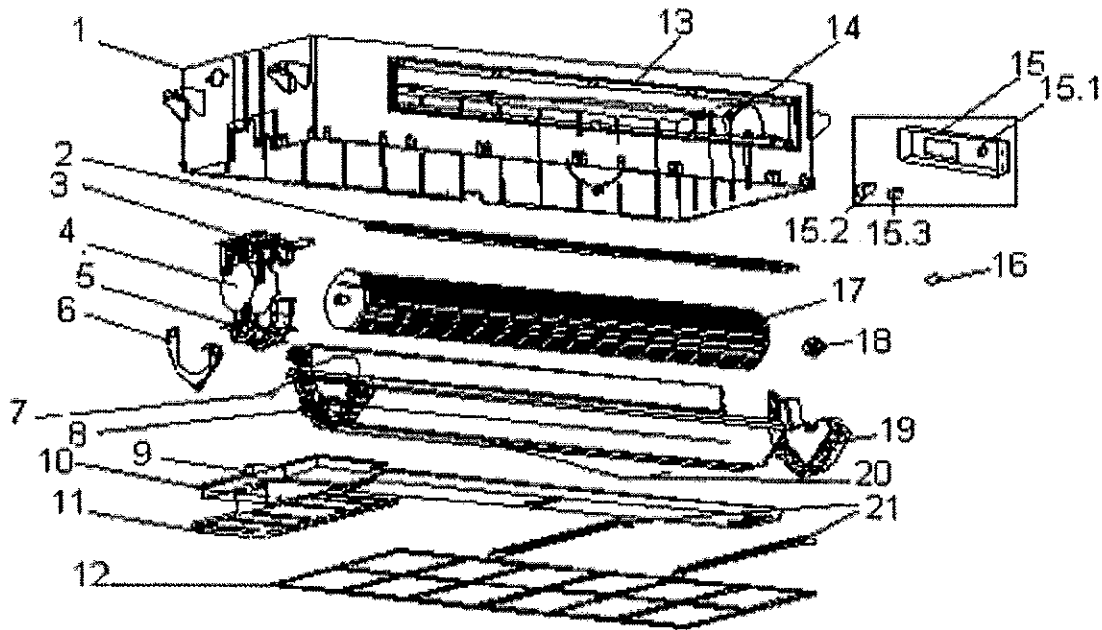

No.	Part Name	Quantity	SALE CODE	BOM CODE
1	Base Plate	1		2118510032
2	Volute organ	1	50412121005	2118615010
3	Holder for fan motor	1	50412121006	2118615002
4	Motor	1	50412121007	2240038002
5	Cover for motor	1	50412121008	2118615003
6	Joint board of Evaporator	1	50412121009	2128615005
7	Evaporator out temperature sensor	1	50224121048	2244200406
8	Evaporator	1		2158619011
9	Outlet pipe	1	31009321020	2112040701
10	Water collector	1		2118615006
11	Protection cover of water collector	1	50412121012	2128615001
12	Air filter	1	50412121013	2118615004
13	Air-passage installation board	1	50412121014	2128000023
14	Room temperature sensor	1	53930121801	2230131063
15	Indoor E-box	1		2335229000
15.1	Transformer	1	50448122007	2230090093
15.2	Capacitor box	1	50526121004	2128000014

15.3	Fan capacitor	1	52503121007	2240110004
15.4	Main control board	1		2135229000
16	Display board assembly	1	50518121028	2334209023
17	Centrifugal fan	1	50412121016	2118615005
18	Bearing seat	1	12818111015	2273050001
19	Left fixing board of evaporator	1	50412121017	2118615008
20	Evaporator middle temperature sensor	1	50412121018	2248615220
21	Fixing clamp for water collector	2	50412121019	2128615000
22	Remote controller	1	10718121008	2335509100
23	Holder for remote controller	1	10718121009	2113139022

### SMF-D18AI

#### Exploded View Parts for

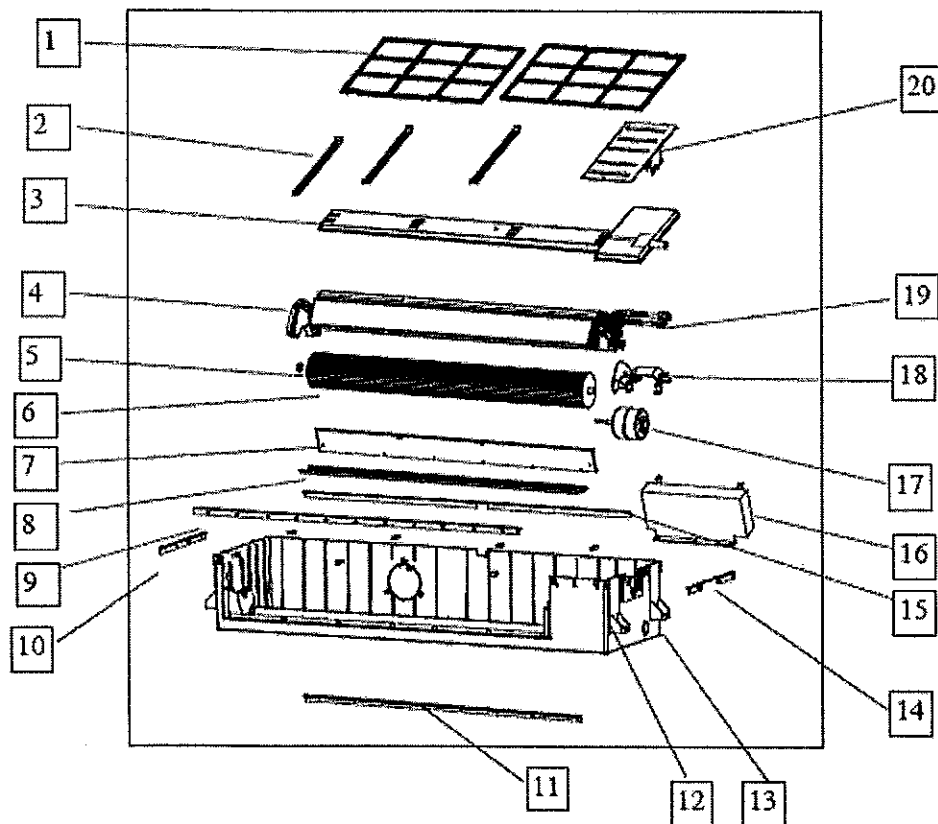

No.	Part Name	Quantity	BOM CODE	Sales code
1	air filter	2	2118615614	
2	Fixing clamp for water collector	3	2128615000	50412121019
3	Water collector	1	2118615611	50412121017
4	Left fixing board of Evaporator	1	2118615008	
5	Bearing seat	1	2273050001	
6	Centrifugal fan	1	2118615615	
7	air-outlet fix board	1	2128615613	

8	Volute organ	1	2118615613
9	air return chamber fix board I	1	2128615611
10	air return chamber fix board III	1	2128615212
11	air-outlet fix string	1	2128615614
12	air filter ballast	8	2118600053
13	Base Plate	1	2118615612
14	air return chamber fix board IV	1	2128615213
15	air return chamber fix board II	1	2128615612
16	Indoor E-box	1	2335229000
17	fan motor	1	2240040616
18	cover for motor	1	2118615610
19	Evaporator	1	2158615610
20	Protection cover of Water collector	1	2128615610

53407121004

SMF-4E27AI

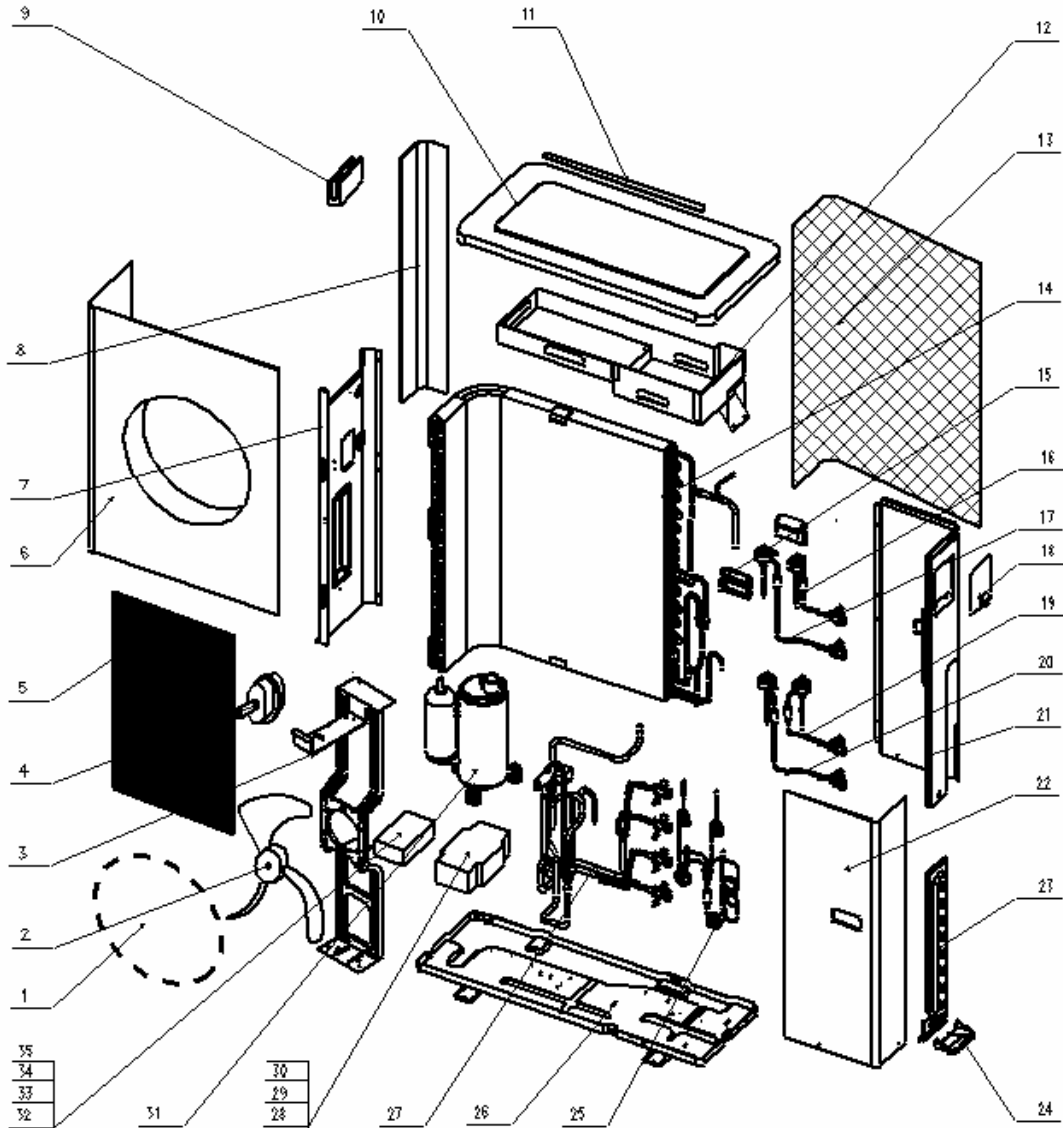

1	Clamp for front net	8	2113511801
2	Propeller fan	1	2114550002
3	Holder for fan motor	1	2123549027
4	fan motor	1	2240041722
5	Front net	1	2124550017
6	Front clapboard	1	2124532935
7	Separating board	1	2124820000
8	Left clapboard	1	2124530063
9	Little handle	1	2115029006
10	Cover	1	2124532936
11	Supporter of back	1	2124532912
12	electrical box assembly	1	2335739000
13	Rear net	1	2114820000
14	Condenser Ass'y	1	2154709047
15	Handle	2	2114540003
16	D high pressure valve assembly.	1	2165739017
17	C high pressure valve assembly.	1	2165739004
18	Big handle	1	2115739000
19	B high pressure valve assembly.	1	2165739002
20	A high pressure valve assembly.	1	2165739000
21	Rear right clapboard	1	2125739003
22	Cabinet,Front-Right	1	2124532903
23	installation board for valve	1	2125739002
24	drain pan	1	2113560000
25	Capillary pipe Ass'y	1	2165739006
26	Base Pan Ass'y	1	2125739004
27	four way valve assembly	1	2165739019
28	inductance box	1	2125019019
29	reactance	1	2230100814
30	reactance	1	2230100815
31	Compressor	1	2140062190
32	upper cover of inductance	1	2125020303
33	base of inductance	1	2125020305
34	surrounding board for inductance	1	2125020306
35	reactance	1	2230100810